



**CTS (NINGBO) TESTING SERVICE TECHNOLOGY  
INTERNATIONAL**

**OPERATE ACCORDING TO ISO/IEC 17025**

# **EMC TEST REPORT**

**TEST REPORT NUMBER : CNB3150930-00721-E**



CTS (Ningbo) Testing Service Technology Co., Ltd.  
2/F., South Tower, Huoju Building, No.181, Canghai Road,  
Jiangdong Science and Technology Park, Ningbo, Zhejiang, China

<b>TEST REPORT</b> <b>EN 50083-2:2012</b>	
Cable networks for television signals, sound signals and interactive services — Part 2: Electromagnetic compatibility for equipment	
<b>Report Reference No.</b> .....	CNB3150930-00721-E
<b>Date of issue</b> .....	14 October 2015
<b>Testing Laboratory Name</b> .....	<b>CTS (Ningbo) Testing Service Technology Co., Ltd.</b>
<b>Address</b> .....	GZ test site: A101, No.65, Zhuji Highway, Tianhe District, Guangzhou, Guangdong, China
<b>Testing location/ procedure</b> .....	Full application of Harmonised standards <input checked="" type="checkbox"/> Partial application of Harmonised standards <input type="checkbox"/> Other standard testing method <input type="checkbox"/>
<b>Applicant's name</b> .....	Chinabase Industrial Co., Ltd.
<b>Address</b> .....	Chenguang Road, Lishui Yongyang town, Nanjing, Jiangsu
<b>Test specification:</b>	
<b>Standard</b> .....	<b>EN 50083-2:2012</b>
<b>Test Report Form No.</b> .....	CTSEMC-1.0
<b>TRF Originator</b> .....	CTS (Ningbo) Testing Service Technology Co., Ltd.
<b>Master TRF</b> .....	Dated 2009-01
<b>CTS (Ningbo) Testing Service Technology Co., Ltd. All rights reserved.</b>	
This publication may be reproduced in whole or in part for non-commercial purposes as long as the CTS (Ningbo) Testing Service Technology Co., Ltd. is acknowledged as copyright owner and source of the material. CTS (Ningbo) Testing Service Technology Co., Ltd. takes no responsibility for and will not assume liability for damages resulting from the reader's interpretation of the reproduced material due to its placement and context.	
<b>Test item description</b> .....	TV/SAT splitter
<b>Trade Mark</b> .....	/
<b>Manufacturer</b> .....	Chinabase Industrial Co., Ltd.
<b>Model/Type reference</b> .....	CB-SP-08-2
<b>Ratings</b> .....	N/A
<b>Result</b> .....	<b>PASSED</b>

**Compiled by:**

Kate zhang / File administrators

**Supervised by:**

Duke yang / Technique principal

**Approved by:**

Vincent yao / Manager



Copyright of this report is owned by Centre of Testing Service and may not be reproduced other than in full except with the written approval of the issuing Company.

**CTS (Ningbo) Testing Service Technology Co., Ltd.**

2/F., South Tower, Huoju Building, No.181, Canghai Road, Jiangdong Science and Technology Park, Ningbo, Zhejiang, China

Tel: +86-20-85543113 (32 lines)

Fax: +86-20-38780406

Complaint line: +86-20-85533471

E-mail: cts@cts-lab.com.cn

See Reverse For Terms And Conditions of Service

## EMC -- TEST REPORT

<b>Test Report No. :</b> <b>CNB3150930-00721-E</b>	<u>14 October 2015</u> Date of issue
--	---

Type / Model.....	CB-SP-08-2
EUT.....	TV/SAT splitter
<b>Applicant</b> .....	Chinabase Industrial Co., Ltd.
Address.....	Chenguang Road, Lishui Yongyang town, Nanjing, Jiangsu
Telephone.....	+86-25-83472872
Fax.....	+86-25-83410082
Contact.....	Qiu Wen
<b>Manufacturer</b> .....	Chinabase Industrial Co., Ltd.
Address.....	Chenguang Road, Lishui Yongyang town, Nanjing, Jiangsu
Telephone.....	+86-25-83472872
Fax.....	+86-25-83410082
Contact.....	Qiu Wen
<b>Factory</b> .....	Chinabase Industrial Co., Ltd.
Address.....	Chenguang Road, Lishui Yongyang town, Nanjing, Jiangsu
Telephone.....	+86-25-83472872
Fax.....	+86-25-83410082
Contact.....	Qiu Wen

The test report merely corresponds to the test sample.  
It is not permitted to copy extracts of these test result without the written permission of the test laboratory.

## TABLE OF CONTENTS

Description	Page
1 TEST STANDARDS .....	4
2 SUMMARY .....	4
2.1 GENERAL REMARKS .....	4
2.2 FINAL ASSESSMENT .....	4
3 EQUIPMENT UNDER TEST .....	5
3.1 Power supply system utilised .....	5
3.2 Short description of the Equipment under Test (EUT) .....	5
3.3 EUT operation mode .....	5
3.4 EUT configuration.....	6
3.5 Performance level.....	6
3.6 Definition related to the performance level .....	6
4 TEST ENVIRONMENT .....	7
4.1 Address of the test laboratory .....	7
4.2 Test facility .....	7
4.3 Environmental conditions .....	7
4.4 Definitions of symbols used in this test report.....	7
4.5 Statement of the measurement uncertainty .....	7
4.6 Measurement Uncertainty.....	8
4.7 Test Description.....	8
5 TEST CONDITIONS AND RESULTS .....	9
5.1 MEASUREMENT OF LOCAL OSCILLATOR POWER.....	9
5.2 MEASUREMENT OF INPUT TERMINAL DISTURBANCE VOLTAGE .....	11
5.3 RADIATION IN THE FREQUENCY RANGE 5MHz TO 25GHz .....	13
5.4 EXTERNAL IMMUNITY TO AMBIENT FIELDS OUT-OF-BAND IMMUNITY .....	16
5.5 EXTERNAL IMMUNITY TO AMBIENT FIELDS INBAND IMMUNITY.....	18
5.6 IMMUNITY TO IMAGE FREQUENCY SIGNALS .....	20
5.7 ELECTROSTATIC DISCHARGE.....	21
6 USED TEST EQUIPMENT .....	23
7 EXTERNAL AND INTERNAL PHOTOS OF THE EUT .....	26
8 Manufacturer/ Approval holder Declaration .....	29

Copyright of this report is owned by Centre of Testing Service and may not be reproduced other than in full except with the written approval of the issuing Company.

### CTS (Ningbo) Testing Service Technology Co., Ltd.

2/F., South Tower, Huoju Building, No.181, Canghai Road, Jiangdong Science and Technology Park, Ningbo, Zhejiang, China

Tel: +86-20-85543113 (32 lines)

Fax: +86-20-38780406

Complaint line: +86-20-85533471

E-mail: cts@cts-lab.com.cn

See Reverse For Terms And Conditions of Service

## 1 TEST STANDARDS

The tests were performed according to following standards:

[EN 50083-2:2012](#) Cable networks for television signals, sound signals and interactive services —  
Part 2: Electromagnetic compatibility for equipment

## 2 SUMMARY

### 2.1 GENERAL REMARKS

Date of receipt of test sample	10 October 2015
Testing commenced on	10 ~ 14 October 2015
Testing concluded on	14 October 2015

### 2.2 FINAL ASSESSMENT

The EMC requirements pertaining to the technical standards and tested operation modes are

- fulfilled.
- **not** fulfilled.

The equipment under test

- fulfils the EMC requirements cited on page 1.
- **does not** fulfil the EMC requirements cited on page 1.



### 3 EQUIPMENT UNDER TEST

#### 3.1 Power supply system utilised

Power supply voltage :  N/A  
 Other (Specified blank below)

#### 3.2 Short description of the Equipment under Test (EUT)

Number of tested samples: 1  
Serial number: Prototype

#### 3.3 EUT operation mode

The equipment under test was operated during the measurement under the following conditions:

- Normal

Operation mode 1 : Normal

Emissions tests.....: According to EN 50083-2, searching for the highest disturbance.

Immunity tests ..... : According to EN 50083-2, searching for the highest susceptibility.

### 3.4 EUT configuration

(The CDF filled by the applicant can be viewed at the test laboratory.)

**The following peripheral devices and interface cables were connected during the measurement:**

Not Applicable

### 3.5 Performance level

The test results shall be classified in terms of the loss of function or degradation of performance of the equipment under test, relative to a performance level defined by its manufacturer or the requestor of the test, or agreed between the manufacturer and the purchaser of the product.

### 3.6 Definition related to the performance level

- based on the used product standard
- based on the declaration of the manufacturer, requestor or purchaser

#### **Criterion A:**

Definition: normal performance within limits specified by the manufacturer, requestor or purchaser:

#### **Criterion B:**

Definition: temporary loss of function or degradation of performance which ceases after the disturbance ceases, and from which the equipment under test recovers its normal performance, without operator intervention:

#### **Criterion C:**

Definition: temporary loss of function or degradation of performance, the correction of which requires operator intervention:

#### **Criterion D:**

Definition: loss of function or degradation of performance, which is not recoverable, owing to damage to hardware or software, or loss of data:

## 4 TEST ENVIRONMENT

### 4.1 Address of the test laboratory

GZ test site: A101, No.65, Zhuji Road, Tianhe District, Guangzhou, Guangdong, China

Tel: +86-20-85543113 (32 lines)

Fax: +86-20-38780406

### 4.2 Test facility

The test facility is recognized, certified, or accredited by the following organizations:

#### CNAS-Lab Code: L3394

CTS (Ningbo) Testing Service Technology Co., Ltd. has been assessed and proved to be in compliance with CNAS-CL01: 2006 Accreditation Criteria for Testing and Calibration Laboratories (identical to ISO/IEC 17025: 2005 General Requirements) for the Competence of Testing and Calibration Laboratories.

#### IC-Registration No.: 8374A

The 3m Alternate Test Site of CTS (Ningbo) Testing Service Technology Co., Ltd. has been registered by Certification and Engineering Bureau of Industry Canada for the performance of radiated measurements with Registration No. 8374A on May 22, 2014.

#### FCC-Registration No.: 971995

CTS (Ningbo) Testing Service Technology Co., Ltd. EMC Laboratory has been registered and fully described in a report filed with the FCC (Federal Communications Commission). The acceptance letter from the FCC is maintained in our files. Registration No.971995, July 13, 2012.

### 4.3 Environmental conditions

During the measurement the environmental conditions were within the listed ranges:

Temperature:	15~35 ° C
Humidity:	25~75 %
Atmospheric pressure:	86~106 kPa

### 4.4 Definitions of symbols used in this test report

- - The black square indicates that the listed condition, standard or equipment is applicable for this report.
- - The empty square indicates that the listed condition, standard or equipment is **not** applicable for this report.

### 4.5 Statement of the measurement uncertainty

The data and results referenced in this document are true and accurate. The reader is cautioned that there may be errors within the calibration limits of the equipment and facilities. The measurement uncertainty was calculated for all measurements listed in this test report acc. to CISPR 16 - 4 "Specification for radio disturbance and immunity measuring apparatus and methods – Part 4: Uncertainty in EMC Measurements" and is documented in the CTS quality system acc. to DIN EN ISO/IEC 17025. Furthermore, component and process variability of devices similar to that tested may result in additional deviation. The manufacturer has the sole responsibility of continued compliance of the device.



#### 4.6 Measurement Uncertainty

Test Item	Frequency Range	Uncertainty	Note
Conduction disturbance	150kHz~30MHz	±1.22dB	(1)
Power disturbance	30MHz~300MHz	±1.38dB	(1)
Radiation emission (3m)	30MHz~300MHz	±3.14dB	(1)
	300MHz~1000MHz	±3.18dB	(1)

(1). This uncertainty represents an expanded uncertainty expressed at approximately the 95% confidence level using a coverage factor of  $k=2$

(2). The actual EUT tested items in this test report, only applies to this "measurement uncertainty" in part / all of the corresponding data.

#### 4.7 Test Description

EMISSION PARAMETERS			
Description of Test Item	Standard	Limits	Results
Conducted disturbance at mains terminals	EN50083-2:2012	-----	N/A
Measurement of input terminal disturbance voltage	EN50083-2:2012	-----	PASS
Radiation in the frequency range 5MHz to 30MHz	EN50083-2:2012	-----	PASS
Radiation in the frequency range 30MHz to 950MHz	EN50083-2:2012	-----	PASS
Radiation in the frequency range 950MHz to 25GHz	EN50083-2:2012	-----	PASS
Disturbance voltages form equipment at the AC mains frequency and its harmonics	EN 61000-3-2:2014	Class A	N/A
IMMUNITY PARAMETERS			
Description of Test Item	Basic Standard	Performance Criteria	Results
Electrostatic discharge (ESD)	EN50083-2:2012	B	PASS
Electrical fast transient (EFT)	EN50083-2:2012	A	N/A
External immunity to ambient fields:Out-of-band immunity	EN50083-2:2012	A	PASS
External immunity to ambient fields:In-band immunity	EN50083-2:2012	A	PASS
Immunity of outdoor units to image frequency signals	EN50083-2:2012	A	PASS
N/A is an abbreviation for Not Applicable.			

Copyright of this report is owned by Centre of Testing Service and may not be reproduced other than in full except with the written approval of the issuing Company.

#### CTS (Ningbo) Testing Service Technology Co., Ltd.

2/F., South Tower, Huoju Building, No.181, Canghai Road, Jiangdong Science and Technology Park, Ningbo, Zhejiang, China

Tel: +86-20-85543113 (32 lines)

Fax: +86-20-38780406

Complaint line: +86-20-85533471

E-mail: cts@cts-lab.com.cn

See Reverse For Terms And Conditions of Service

## 5 TEST CONDITIONS AND RESULTS

### 5.1 MEASUREMENT OF LOCAL OSCILLATOR POWER

For test instruments and accessories used see section 6 part 6.2.

#### 5.2.1 Description of the test location

Test location : Semi-Anechoic chamber

Test disturbance: 3 Meter

#### 5.1.2. Test procedures

Measurements shall be made by the substitution method with the antenna having both horizontal and vertical polarisations and the turntable with the equipment under test shall be rotated. The equipment shall be rotated in all planes. The highest level of radiation measured shall be noted at each measuring frequency.

Then the equipment under test is replaced by a calibrated transmitting antenna supplied by a standard generator. Its centre shall be placed in the same initial position of the equipment centre according to (5.2.3 Block Diagram of Test Setup).

For each measuring frequency the output level of the generator is adjusted in order to give the same reference indication on the spectrum analyser as achieved with the EUT. The level of the available power of the generator, increased by the radiating antenna gain above the half-wave dipole, is taken as the level of the radiated power of the equipment under test at the considered frequency.

NOTE 2 The equivalent radiated power is given by the following equation:

$$P = P_g \uparrow A_c + G_a$$

where:

$P$  is the equivalent radiated power in dB(pW);

$P_g$  is the available power of the generator in dB(pW);

$A_c$  is the loss of any cables and adaptors between generator and antenna in dB;

$G_a$  is the gain of the transmitting antenna in dB referred to the half-wave dipole antenna.

It shall be ascertained that, when the equipment under test is switched off, the level of back-ground noise is at least 10 dB below the relevant limit, otherwise the reading may be significantly affected.

#### 5.1.3 Block Diagram of Test Setup

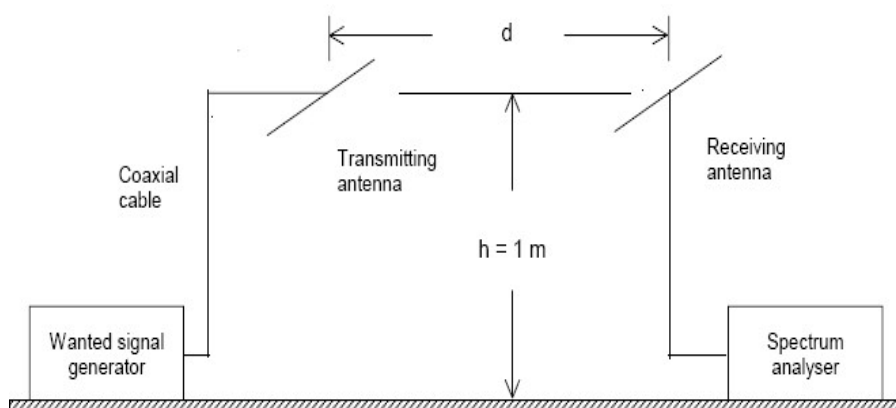

Copyright of this report is owned by Centre of Testing Service and may not be reproduced other than in full except with the written approval of the issuing Company.

#### CTS (Ningbo) Testing Service Technology Co., Ltd.

2/F., South Tower, Huoju Building, No.181, Canghai Road, Jiangdong Science and Technology Park, Ningbo, Zhejiang, China

Tel: +86-20-85543113 (32 lines)

Fax: +86-20-38780406

Complaint line: +86-20-85533471

E-mail: cts@cts-lab.com.cn

See Reverse For Terms And Conditions of Service

## 5.1.4 Limits

Frequency (GHz)	Level dB (pW)
2.5 to 25	30

## 5.1.5 Test result

Frequency range (GHz)	Test Results
2.5 to 25	Margin>10dB pW, Passed

Copyright of this report is owned by Centre of Testing Service and may not be reproduced other than in full except with the written approval of the issuing Company.

**CTS (Ningbo) Testing Service Technology Co., Ltd.**

2/F., South Tower, Huoju Building, No.181, Canghai Road, Jiangdong Science and Technology Park, Ningbo, Zhejiang, China

Tel: +86-20-85543113 (32 lines)

Fax: +86-20-38780406

Complaint line: +86-20-85533471

E-mail: cts@cts-lab.com.cn

See Reverse For Terms And Conditions of Service

## 5.2 MEASUREMENT OF INPUT TERMINAL DISTURBANCE VOLTAGE

For test instruments and accessories used see section 6 part 6.3.

### 5.2.1 LIMITS

Frequency range (MHz)	Oscillator frequency	Level(75Ω) dB(μV)
30 to 3000	Fundamental	46
30 to 3000	Harmonics	46

### 5.2.2 TEST PROCEDURES

#### 5.2.2.1 Procedure of Preliminary Test

- The equipment was set up as per the test configuration to simulate typical usage per the user's manual. The EUT was placed on a wooden table with a height of 0.8 meters was used that was placed on the ground plane.
- Support equipment, if needed, was placed as per EN 55013.
- All I/O cables were positioned to simulate typical usage as per EN 55013.
- The EUT received AC power source, from the outlet socket. All support equipment received power was from another socket.
- Added a 75Ω ↔ 50Ω matching network, between EUT and EMI test receiver to get impedance match condition during the test.
- The output level of the auxiliary signal generator shall be set to give the value of 60 dB (μV) for FM receiver or 70 dB (μV) for TV and VCR to the input of the frequency-modulation or television receiver (or video recorder) respectively, on a 75Ω impedance. An additional amplifier should be inserted at the generator output, if necessary.
- The results shall be expressed in the terms of the substitution voltage in decibels (μV), as supplied by the standard signal generator. The specified source impedance of the receiver shall be stated with the results.
- When measurements are made at the antenna terminals of the EUT, an auxiliary signal generator shall be used to feed the equipment under test input with a standard test signal (see sub clause 5.1.1 of CISPR 13/ EN 55013) at the receiver tuning frequency (30MHz to 2150MHz).
- The test mode(s) described in Item 3.3 were scanned during the preliminary test:
- After the preliminary scan, we found the test mode described in Item 3.3 producing the highest emission level.
- The EUT and cable configuration of the above highest emission levels were recorded for the final test.

#### 5.2.2.2 Procedure of Final Test

- EUT and support equipment were set up on the table as per the configuration with highest emission level in the preliminary test.
- The Analyzer / Receiver scanned from 30MHz to 2150MHz. recorded the value, the local frequency, amplitude, were recorded in which correction factors were used to calculate the emission level and compare reading to the applicable limit, and only Q.P reading will record in this report.

Copyright of this report is owned by Centre of Testing Service and may not be reproduced other than in full except with the written approval of the issuing Company.

#### CTS (Ningbo) Testing Service Technology Co., Ltd.

2/F., South Tower, Huoju Building, No.181, Canghai Road, Jiangdong Science and Technology Park, Ningbo, Zhejiang, China

Tel: +86-20-85543113 (32 lines)

Fax: +86-20-38780406

Complaint line: +86-20-85533471

E-mail: cts@cts-lab.com.cn

See Reverse For Terms And Conditions of Service

- Recorded at least the six highest emissions. Emission frequencies, amplitude were recorded into a computer in which correction factors were used to calculate the emission level and compare reading to the applicable limit and only Q.P. reading is presented.
- The test data of the worst-case condition(s) was recorded.

### 5.2.3 TEST RESULTS

Frequency range (MHz)	Oscillator frequency	Test Results
30 to 3000	Fundamental	Margin>6dB, Passed
30 to 3000	Harmonics	Margin>6dB, Passed

Copyright of this report is owned by Centre of Testing Service and may not be reproduced other than in full except with the written approval of the issuing Company.

**CTS (Ningbo) Testing Service Technology Co., Ltd.**

2/F., South Tower, Huoju Building, No.181, Canghai Road, Jiangdong Science and Technology Park, Ningbo, Zhejiang, China

Tel: +86-20-85543113 (32 lines)

Fax: +86-20-38780406

Complaint line: +86-20-85533471

E-mail: cts@cts-lab.com.cn

See Reverse For Terms And Conditions of Service

### 5.3 RADIATION IN THE FREQUENCY RANGE 5MHz TO 25GHz

For test instruments and accessories used see section 6 part 6.4

#### 5.3.1 LIMITS

Frequency range MHz	Limit values dB(pW)	Measuring bandwidth kHz	Detector
5 to 30	27 – 20 <sup>1), 2)</sup>	9	quasi-peak
5 to 30	33 <sup>3)</sup>	9	quasi-peak
30 to 950	20	120	quasi-peak
950 to 2 500	43	1 000	peak
2 500 to 25 000	57	1 000	peak
<sup>1)</sup> Decreasing linearly with the logarithm of frequency <sup>2)</sup> For active equipment which is not powered via a mains line <sup>3)</sup> For mains powered equipment			
NOTE The limit of 50 dB(μV) for disturbance voltages on the mains line in the frequency range 5 MHz to 30 MHz is corresponding to a radiated disturbance power of 33 dB(pW). To avoid different limits for the mains line and other ports the radiation requirements for equipment having a mains line is increased to 33 dB(pW).			

#### 5.3.2 TEST PROCEDURES

##### 5.3.2.1. 5MHz to 30MHz test procedures

The generator for the wanted signal is adjusted to the required test frequency and its level is set to the maximum specified operating level at the output of the equipment. The measuring receiver is successively connected to all coupling units. All unused ports shall be terminated. For each measuring frequency the maximum reading is noted.

##### 5.3.2.2. 30MHz to 950MHz test procedures

With the equipment set-up as shown in Figure 2 and Figure 3, and the measurement cable coupled to an output port of the equipment under test, the absorbing clamp is positioned at the equipment end of the measurement cable and the coaxial switch placed in the "check level" position. Adjust the signal generator to the test frequency and to an input level that will give the maximum rated output level from the equipment under test.

Tune the measuring set. Turn the coaxial switch to the "measure radiation" mode. Move the absorbing clamp along the cable away from the equipment until a maximum reading is obtained on the measuring set (at a spacing of about  $\lambda/2$ ).

This procedure is repeated for each of the test frequencies and for each of the measurement ports.

For radiation measurements on a frequency converter output port, note that the input signal generator shall be set in turn to the input frequencies used and the measuring set tuned to each of the particular output frequencies.

For radiation measurements on the mains lead of active equipment, the equipment shall be connected as shown in (5.4.2 Block Diagram of Test Setup 1), except that the mains lead without absorbing devices, extended if necessary, shall

pass through the absorbing clamp in place of the measurement cable. Measurements shall be carried out as described above except that the "check-level" position of the coaxial switch is inoperative with this arrangement. Set the signal generator output level to that used when measuring the output port.

Copyright of this report is owned by Centre of Testing Service and may not be reproduced other than in full except with the written approval of the issuing Company.

#### CTS (Ningbo) Testing Service Technology Co., Ltd.

2/F., South Tower, Huoju Building, No.181, Canghai Road, Jiangdong Science and Technology Park, Ningbo, Zhejiang, China

Tel: +86-20-85543113 (32 lines)

Fax: +86-20-38780406

Complaint line: +86-20-85533471

E-mail: cts@cts-lab.com.cn

See Reverse For Terms And Conditions of Service

**5.3.2.2. 950MHz to 25GHz test procedures**

Measurements shall be made by the substitution method with the antenna having both horizontal and vertical polarisations and the turntable with the equipment under test shall be rotated. The equipment shall be rotated in all planes. The highest level of radiation measured shall be noted at each measuring frequency.

Then the equipment under test is replaced by a calibrated transmitting antenna supplied by a standard generator. Its centre shall be placed in the same initial position of the equipment centre according to (5.4.2 Block Diagram of Test Setup 2).

For each measuring frequency the output level of the generator is adjusted in order to give the same reference indication on the spectrum analyser as achieved with the EUT. The level of the available power of the generator, increased by the radiating antenna gain above the half-wave dipole, is taken as the level of the radiated power of the equipment under test at the considered frequency.

NOTE 2 The equivalent radiated power is given by the following equation:

$$P = P_g \uparrow A_c + G_a$$

where:

$P$  is the equivalent radiated power in dB(pW);

$P_g$  is the available power of the generator in dB(pW);

$A_c$  is the loss of any cables and adaptors between generator and antenna in dB;

$G_a$  is the gain of the transmitting antenna in dB referred to the half-wave dipole antenna.

It shall be ascertained that, when the equipment under test is switched off, the level of back-ground noise is at least 10 dB below the relevant limit, otherwise the reading may be significantly affected.

**5.3.2 Block Diagram of Test Setup**

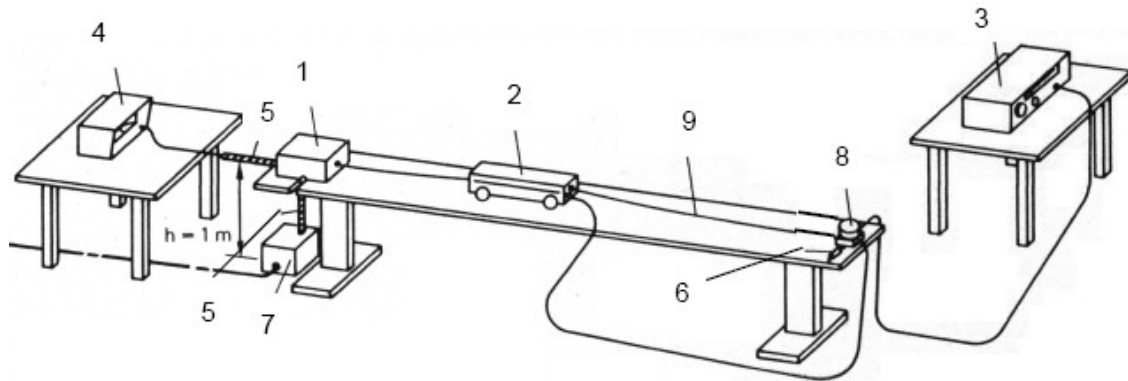

- |                          |                          |                              |
|--------------------------|--------------------------|------------------------------|
| 1 = equipment under test | 6 = terminating resistor | Coaxial switch: Switch-Pos   |
| 2 = absorbing clamp      | 7 = mains filter         | Measure radiation 3 - 2, 6 9 |
| 3 = measuring set        | 8 = coaxial switch       | Check level 3 - 9, (6 - 2)   |
| 4 = signal generator     | 9 = measurement cable    |                              |
| 5 = absorbing device     |                          |                              |

5.3.2. Block Diagram of Test Setup 1

Copyright of this report is owned by Centre of Testing Service and may not be reproduced other than in full except with the written approval of the issuing Company.

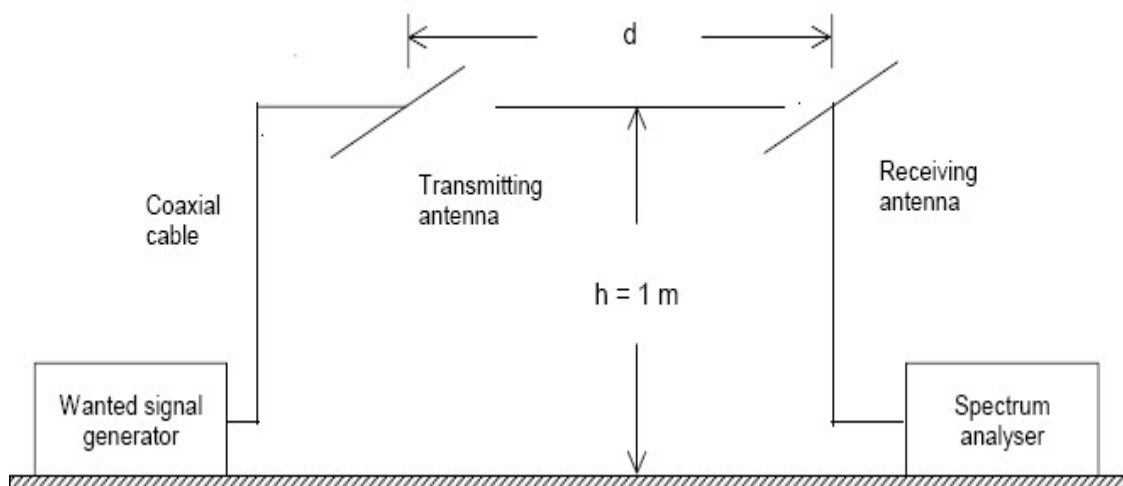

5.3.2. Block Diagram of Test Setup 2

5.3.3 TEST RESULTS

Frequency range (MHz)	Test Results
5 to 30	Margin>6dB, Passed
30 to 950	Margin>6dB, Passed
950 to 25000	Margin>6dB, Passed

Copyright of this report is owned by Centre of Testing Service and may not be reproduced other than in full except with the written approval of the issuing Company.



**5.4 EXTERNAL IMMUNITY TO AMBIENT FIELDS OUT-OF-BAND IMMUNITY**

For test instruments and accessories used see section 6 part 6.6

5.4.1 Description of the test location

Test location :	GTEM chamber
Test condition:	Ambient Temperature: 24°C, Humidity:56%
Date of test :	10~14 October 2015
Operator :	<b>Eric</b>

5.4.2 Severity levels of electromagnetic field

Frequency Range (MHz)	Level(dBuV)
0.15~80	125

Frequency Range (MHz)	Field strenght(dBuV/m)
80~3000	125

Note: Performance criterion: A

5.4.3 Description of the test set-up

5.4.3.1 Operating Condition

The EUT is normal during the test, and the results of the maximum emanation are recorded

5.4.3.2 Block Diagram of Test Setup

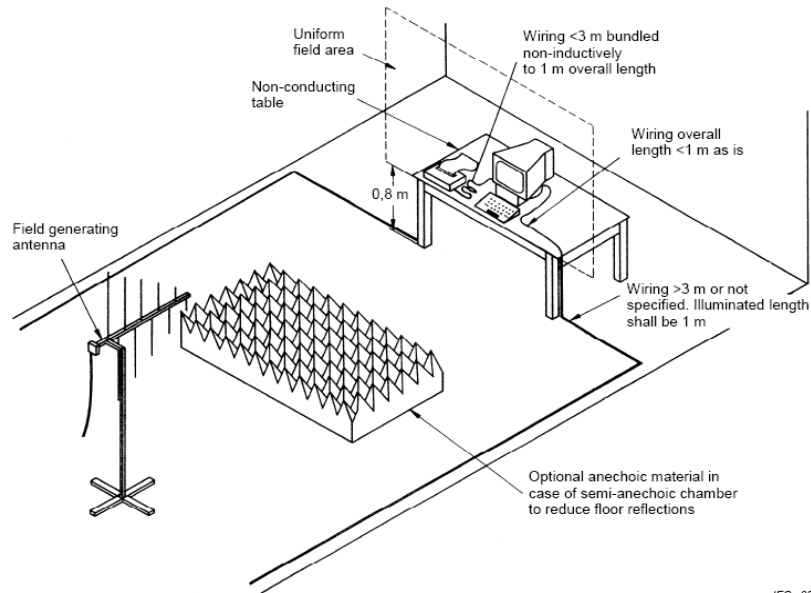

IEC 034/06

Copyright of this report is owned by Centre of Testing Service and may not be reproduced other than in full except with the written approval of the issuing Company.

**CTS (Ningbo) Testing Service Technology Co., Ltd.**

2/F., South Tower, Huoju Building, No.181, Canghai Road, Jiangdong Science and Technology Park, Ningbo, Zhejiang, China

Tel: +86-20-85543113 (32 lines)

Fax: +86-20-38780406

Complaint line: +86-20-85533471

E-mail: cts@cts-lab.com.cn

See Reverse For Terms And Conditions of Service

## 5.4.4 Test specification:

Frequency range:	<input checked="" type="checkbox"/> 0.15 MHz to 80 MHz
	<input checked="" type="checkbox"/> 80 MHz to 3000 MHz
Level for 0.15 MHz to 80 MHz	<input checked="" type="checkbox"/> 125dBuV
Field strength for 80 MHz to 3000 MHz	<input checked="" type="checkbox"/> 125dBuV/M
EUT - antenna separation:	<input checked="" type="checkbox"/> 3 m
Frequency step:	<input checked="" type="checkbox"/> 1 % with 3 s dwell time
Antenna polarisation:	<input checked="" type="checkbox"/> horizontal <input checked="" type="checkbox"/> vertical

## 5.4.5 Test result

The requirements are **Fulfilled**Performance Criterion: **A****Remarks:** During the test no deviation was detected to the selected operation mode(s).

**5.5 EXTERNAL IMMUNITY TO AMBIENT FIELDS INBAND IMMUNITY**

For test instruments and accessories used see section 6 part 6.6.

5.5.1 Description of the test location

Test location :	GTEM chamber
Test condition:	Ambient Temperature: 24°C, Humidity:56%
Date of test :	10~14 October 2015
Operator :	<b>Eric</b>

5.5.2 Severity levels of electromagnetic field

Frequency Range (MHz)	Level(dBuV)
0.15~80	106

Frequency Range (MHz)	Field strenght(dBuV/m)
80~3000	106

Note: Performance criterion: A

5.5.3 Description of the test set-up

5.5.3.1 Operating Condition

The EUT is normal during the test, and the results of the maximum emanation are recorded

5.5.3.2 Block Diagram of Test Setup

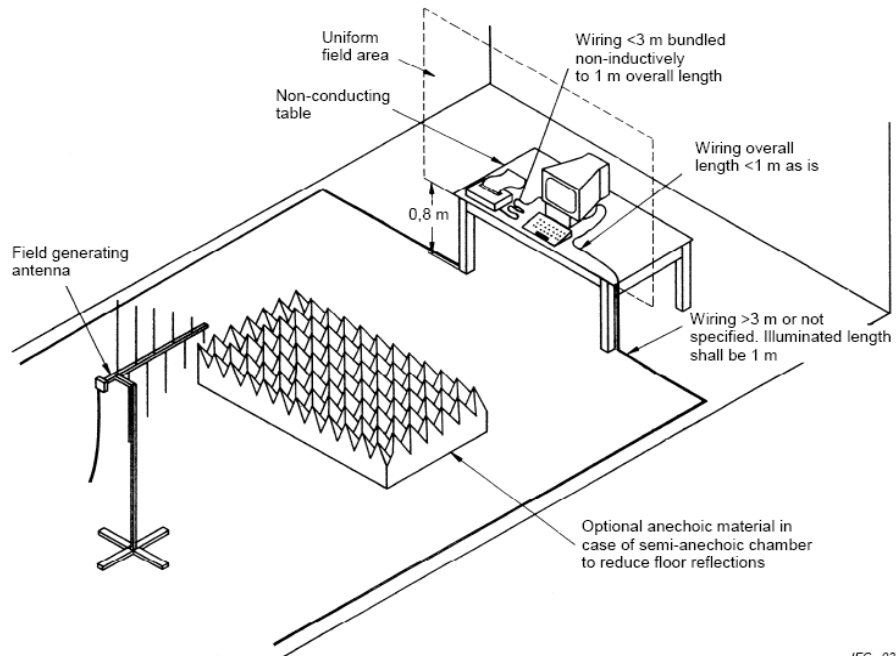

Copyright of this report is owned by Centre of Testing Service and may not be reproduced other than in full except with the written approval of the issuing Company.

**CTS (Ningbo) Testing Service Technology Co., Ltd.**

2/F., South Tower, Huoju Building, No.181, Canghai Road, Jiangdong Science and Technology Park, Ningbo, Zhejiang, China

Tel: +86-20-85543113 (32 lines)

Fax: +86-20-38780406

Complaint line: +86-20-85533471

E-mail: cts@cts-lab.com.cn

See Reverse For Terms And Conditions of Service

## 5.5.4 Test specification:

Frequency range:	<input checked="" type="checkbox"/> 0.15 MHz to 80 MHz
	<input checked="" type="checkbox"/> 80 MHz to 3000 MHz
Level for 0.15 MHz to 80 MHz	<input checked="" type="checkbox"/> 125dBuV
Field strength for 80 MHz to 3000 MHz	<input checked="" type="checkbox"/> 125dBuV/M
EUT - antenna separation:	<input checked="" type="checkbox"/> 3 m
Frequency step:	<input checked="" type="checkbox"/> 1 % with 3 s dwell time
Antenna polarisation:	<input checked="" type="checkbox"/> horizontal <input checked="" type="checkbox"/> vertical

## 5.5.5 Test result

The requirements are **Fulfilled**Performance Criterion: **A****Remarks:** During the test no deviation was detected to the selected operation mode(s).

## 5.6 IMMUNITY TO IMAGE FREQUENCY SIGNALS

### 5.6.1 Description of the test location

Test location :	EMS Room
Test condition:	Ambient Temperature: 24°C, Humidity:56%
Date of test :	10~14 October 2015
Operator :	<b>Eric</b>

### 5.6.2 Test Limit

Type of equipment	Output frequency MHz	Limit Values dB
Outdoor units	950 to 3000	40

### 5.6.3 Test Procedures

The immunity to image frequency signals is given by the image frequency rejection ratio. It shall be measured for outdoor units used for the reception and conversion of FM-TV-signals with output frequencies in the SAT-IF-range.

### 5.6.4 Test result

The requirements are **Fulfilled**

Performance Criterion: **A**

### 5.7 ELECTROSTATIC DISCHARGE

For test instruments and accessories used see section 6 part 6.7.

#### 5.7.1 Description of the test location

Test location :	EMS Room
Test condition:	Ambient Temperature: 24°C, Humidity:56%
Date of test :	10~14 October 2015
Operator :	<b>Eric</b>

#### 5.7.2 Severity of levels electrostatic discharge

Port	Charge Voltage KV	Performance Criterion
Enclosure	4	B

#### 5.7.3 Description of the test set-up

##### 5.7.3.1 Operating Condition

The EUT is normal during the test, and the results of the maximum emanation are recorded

##### 5.7.3.2 Block Diagram of Test Setup

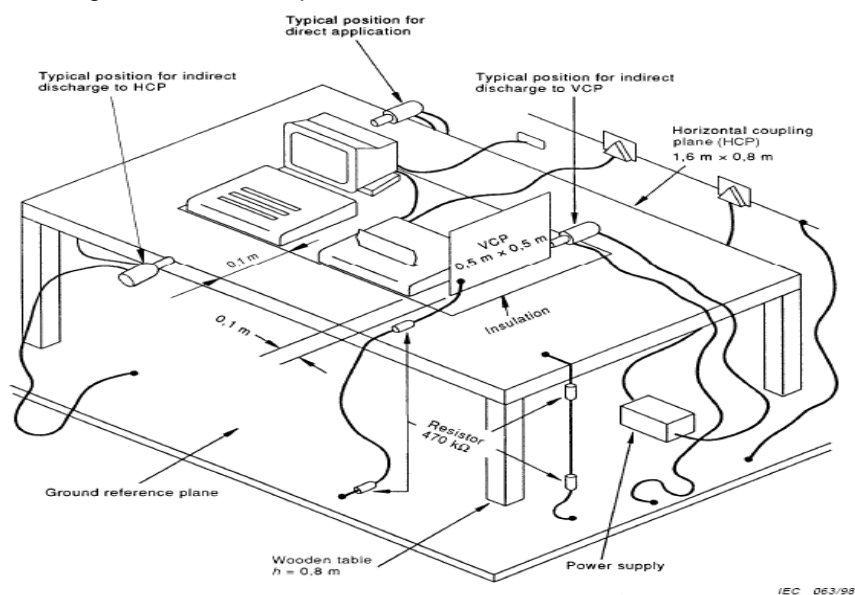

Copyright of this report is owned by Centre of Testing Service and may not be reproduced other than in full except with the written approval of the issuing Company.

**CTS (Ningbo) Testing Service Technology Co., Ltd.**

2/F., South Tower, Huoju Building, No.181, Canghai Road, Jiangdong Science and Technology Park, Ningbo, Zhejiang, China

Tel: +86-20-85543113 (32 lines)

Fax: +86-20-38780406

Complaint line: +86-20-85533471

E-mail: cts@cts-lab.com.cn

See Reverse For Terms And Conditions of Service

## 5.7.4 Test specification:

Enclosure discharge voltage:	<input checked="" type="checkbox"/> 2 kV	<input checked="" type="checkbox"/> 4 kV
Discharge impedance:	<input checked="" type="checkbox"/> 330 $\Omega$ / 150 pF	
Discharge factor:	<input checked="" type="checkbox"/> $\geq 1$ sec.	
Number of discharges:	<input checked="" type="checkbox"/> $\geq 10$	
Type of discharge:	<input type="checkbox"/> Direct discharge	<input checked="" type="checkbox"/> Contact discharge
Polarity:	<input checked="" type="checkbox"/> Positive	<input checked="" type="checkbox"/> Negative
Discharge location:	<input checked="" type="checkbox"/> see photo documentation of the test set-up	
	<input checked="" type="checkbox"/> all external locations accessible by hand	

## 5.7.5 Test result

The requirements are **Fulfilled**Performance Criterion: **B****Remarks:** During the test no deviation was detected to the selected operation mode(s).

## 6 USED TEST EQUIPMENT

### 6.1

Conducted Disturbance					
Item	Test Equipment	Manufacturer	Model No.	Serial No.	Last Cal.
1	EMI Test Receiver	ROHDE & SCHWARZ	ESCI	100868	2014/11/04
2	Artificial Mains	ROHDE & SCHWARZ	ESH3-Z5	832479/025	2014/11/04
3	Artificial Mains	ROHDE & SCHWARZ	ESH3-Z5	100140	2014/11/04
4	Pulse Limiter	ROHDE & SCHWARZ	ESHS-Z2	100301	2014/11/04

### 6.2

MEASUREMENT OF LOCAL OSCILLATOR POWER					
Item	Test Equipment	Manufacturer	Model No.	Serial No.	Last Cal.
1	EMI Test Receiver	ROHDE & SCHWARZ	ESCI	100868	2014/11/04
2	Biconical Antenna	ROHDE & SCHWARZ	HK116	100221	2015/03/24
3	Log per Antenna	ROHDE & SCHWARZ	HL223	100226	2015/03/24
4	Log per Antenna	ROHDE & SCHWARZ	HL050	100186	2015/03/24
5	Signal Generator	Anritsu	MG3694A	1123819	2014/11/04
6	Signal analyze	ROHDE & SCHWARZ	FSIQ26	100311	2015/03/24

### 6.3

MEASUREMENT OF INPUT TERMINAL DISTURBANCE VOLTAGE					
Item	Test Equipment	Manufacturer	Model No.	Serial No.	Last Cal.
1	EMI Test Receiver	ROHDE & SCHWARZ	ESCI	100868	2014/11/04
2	Biconical Antenna	ROHDE & SCHWARZ	HK116	100221	2015/03/24
3	Log per Antenna	ROHDE & SCHWARZ	HL223	100226	2015/03/24
4	Log per Antenna	ROHDE & SCHWARZ	HL050	100186	2015/03/24
5	Signal Generator	Anritsu	MG3694A	1123819	2013/11/29
6	Signal analyze	ROHDE & SCHWARZ	FSIQ26	100311	2015/03/24

Copyright of this report is owned by Centre of Testing Service and may not be reproduced other than in full except with the written approval of the issuing Company.

#### CTS (Ningbo) Testing Service Technology Co., Ltd.

2/F., South Tower, Huoju Building, No.181, Canghai Road, Jiangdong Science and Technology Park, Ningbo, Zhejiang, China

Tel: +86-20-85543113 (32 lines)

Fax: +86-20-38780406

Complaint line: +86-20-85533471

E-mail: cts@cts-lab.com.cn

See Reverse For Terms And Conditions of Service



## 6.4

RADIATION IN THE FREQUENCY RANGE 5MHz TO 25GHz					
Item	Test Equipment	Manufacturer	Model No.	Serial No.	Last Cal.
1	EMI Test Receiver	ROHDE & SCHWARZ	ESCI	100868	2014/11/04
2	Biconical Antenna	ROHDE & SCHWARZ	HK116	100221	2015/03/24
3	Log per Antenna	ROHDE & SCHWARZ	HL223	100226	2015/03/24
4	Log per Antenna	ROHDE & SCHWARZ	HL050	100186	2015/03/24
5	Signal Generator	Anritsu	MG3694A	1123819	2013/11/29
6	Signal analyze	ROHDE & SCHWARZ	FSIQ26	100311	2015/03/24
7	RF generator / amplifier	Schlöder	CDG 6000	HU906007	2014/11/04
8	CDN	Schlöder	CDN M3	A3003008	2014/11/04
9	CDN	Schlöde	CDN T2	A3010005	2014/11/04
10	Attenuator	Abschwächer	DC-500MHz	N/A	2014/11/04
11	EM injection clamp	Liithi	EM101	35670	2013/11/06

## 6.5

Harmonic Current					
Item	Test Equipment	Manufacturer	Model No.	Serial No.	Last Cal.
1	Harmonic And Flicker Analyzer	EMC Partner	Harmonics1000-1P	103488	2014/11/04
2	Harmonics-1000	EMC Partner	N/A	N/A	N/A

## 6.6

EXTERNAL IMMUNITY TO AMBIENT FIELDS OUT-OF-BAND/IN BAND IMMUNITY					
Item	Test Equipment	Manufacturer	Model No.	Serial No.	Last Cal.
1	RF generator / amplifier	Schlöder	CDG 6000	HU906007	2014/11/04
2	CDN	Schlöder	CDN M3	A3003008	2014/11/04
3	CDN	Schlöde	CDN T2	A3010005	2014/11/04
4	EM injection clamp	Liithi	EM101	35670	2013/11/06
5	SIGNAL GENERATOR	ROHDE & SCHWARZ	SMY 01	843215/014	2014/11/04
6	AMPLIFIER	KALMUS	713FC	7385-1	2014/11/04
7	Biconical Antenna	ROHDE & SCHWARZ	HK116	100221	2015/03/24
8	Log per Antenna	ROHDE & SCHWARZ	HL223	100226	2015/03/24
9	Log per Antenna	ROHDE & SCHWARZ	HL050	100186	2015/03/24

Copyright of this report is owned by Centre of Testing Service and may not be reproduced other than in full except with the written approval of the issuing Company.

**CTS (Ningbo) Testing Service Technology Co., Ltd.**

2/F., South Tower, Huoju Building, No.181, Canghai Road, Jiangdong Science and Technology Park, Ningbo, Zhejiang, China

Tel: +86-20-85543113 (32 lines)

Fax: +86-20-38780406

Complaint line: +86-20-85533471

E-mail: cts@cts-lab.com.cn

See Reverse For Terms And Conditions of Service

## 6.7

Electrostatic Discharge					
Item	Test Equipment	Manufacturer	Model No.	Serial No.	Last Cal.
1	ESD Simulator	Schlöder	SESD 200	0302016	2015/03/24

## 6.8

Electrical Fast Transient/Burst					
Item	Test Equipment	Manufacturer	Model No.	Serial No.	Last Cal.
1	EMC test system Transient-1000	EMC Partner	Transient- 1000	HAR1000-78	2014/11/04
2	3-Phase Coupling Network	EMC Partner	CDN1000	CDN1000-08	2014/11/04
3	Coupling Clamp	EMC Partner	SFT 410	0302015	2014/11/04
4	Genecs Software	EMC Partner	N/A	N/A	N/A

Copyright of this report is owned by Centre of Testing Service and may not be reproduced other than in full except with the written approval of the issuing Company.

**CTS (Ningbo) Testing Service Technology Co., Ltd.**

2/F., South Tower, Huoju Building, No.181, Canghai Road, Jiangdong Science and Technology Park, Ningbo, Zhejiang, China

Tel: +86-20-85543113 (32 lines)

Fax: +86-20-38780406

Complaint line: +86-20-85533471

E-mail: cts@cts-lab.com.cn

See Reverse For Terms And Conditions of Service

## 7 EXTERNAL AND INTERNAL PHOTOS OF THE EUT



External view 1



External view 2



External view 3

Copyright of this report is owned by Centre of Testing Service and may not be reproduced other than in full except with the written approval of the issuing Company.

**CTS (Ningbo) Testing Service Technology Co., Ltd.**

2/F., South Tower, Huoju Building, No.181, Canghai Road, Jiangdong Science and Technology Park, Ningbo, Zhejiang, China

Tel: +86-20-85543113 (32 lines)

Fax: +86-20-38780406

Complaint line: +86-20-85533471

E-mail: cts@cts-lab.com.cn

See Reverse For Terms And Conditions of Service



**External view 4**



**External view 5**



**External view 6**

Copyright of this report is owned by Centre of Testing Service and may not be reproduced other than in full except with the written approval of the issuing Company.

**CTS (Ningbo) Testing Service Technology Co., Ltd.**

2/F., South Tower, Huoju Building, No.181, Canghai Road, Jiangdong Science and Technology Park, Ningbo, Zhejiang, China

Tel: +86-20-85543113 (32 lines)

Fax: +86-20-38780406

Complaint line: +86-20-85533471

E-mail: [cts@cts-lab.com.cn](mailto:cts@cts-lab.com.cn)

See Reverse For Terms And Conditions of Service



Following Number External view 1

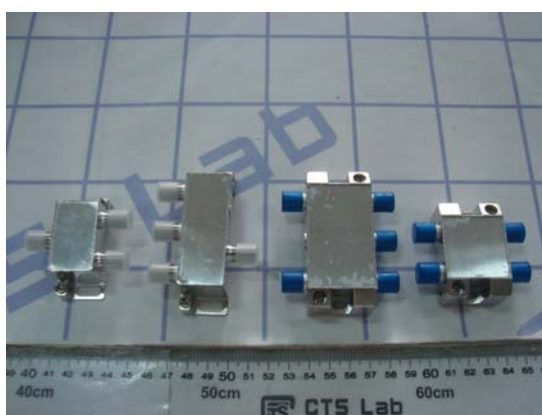

Following Number External view 2

Copyright of this report is owned by Centre of Testing Service and may not be reproduced other than in full except with the written approval of the issuing Company.

**CTS (Ningbo) Testing Service Technology Co., Ltd.**

2/F., South Tower, Huoju Building, No.181, Canghai Road, Jiangdong Science and Technology Park, Ningbo, Zhejiang, China

Tel: +86-20-85543113 (32 lines)

Fax: +86-20-38780406

Complaint line: +86-20-85533471

E-mail: cts@cts-lab.com.cn

See Reverse For Terms And Conditions of Service

## 8 Manufacturer/ Approval holder Declaration

The following identical model(s):

**CB-SP-03-2,   CB-SP-03-3,   CB-SP-03-4,   CB-SP-08-3,  
CB-SP-08-4,   CB-SP-08-6,   CB-SP-08-8**

Belong to the tested device:

Product description: **TV/SAT splitter**  
Model name: **CB-SP-08-2**